

JOHN FIG 74

Safety Relief Valve

The John 74 Safety Relief Valve is engineered with a pivoting disc for precise alignment to the nozzle, ensuring optimal operation. Its top guiding, unobstructed seat bore, and full lift capability guarantee the highest discharge rates, offering maximum plant protection. The inlet pipework should maintain a maximum inlet pressure drop of 3% to handle substantial flows effectively. This valve is available in both wconventional and balanced bellows types, featuring a specialized disc design tailored for liquid applications, enhancing overall valve performance.

Body	CS ASTM A216 Gr WCB (-29° to 427°C)
Trim	Stainless Steel / EPDM EPDM
Size Range	25, 32, 40, 50, 65, 80, 100
Pressure Rating	Variable on Size and Medium
Temperature	Stainless Steel / EPDM (-20°C to 95°C) EPDM – Hot water (-46°C to 150°C)
Connections	Flanged x Flanged
Options	Open Lever / Pressure-tight dome Top Guided / Full Lift
Standards	AS 1271, Class A, BS6759 Pt 1,2,3, ASME- Boiler and Pressure Vessel Code, Section VIII

Dimensions

Type	Size	Inlet	Outlet	A (mm)	B (mm)	C (mm)	Kg
FLANGED	DN25 (1")	25	40	105	423	100	10.7
	DN32 (1-1/4")	32	50	115	467	110	16
	DN40 (1-1/2")	40	65	140	587	115	23
	DN50 (2")	50	80	150	634	120	35
	DN65 (2-1/2")	65	100	170	738	140	51
	DN80 (3")	80	125	195	854	160	75
	DN100 (4")	100	150	220	974	180	100

Materials of Construction

ID	Part Description	Material	Specification
1	Body	CS	ASTM A 216 Gr WCB
2	Seat	SS	AS 2837 Gr 316
3	Stem	SS	AS 2837 Gr 316
4	Spring Cap	SS	AS 2837 Gr 316
5	Spring	AS	50CrVA
6	Adjusting Screw	SS	AS 2837 Gr 410
7	Guide Plate	SS	AS 2837 Gr 316
8	Bush	PTFE	PTFE
9	Bonnet	CS	ASTM A 216 Gr WCB
10	Disc	SS	ASTM A351 Gr CF8M
11	Dome	CS	ASTM A 216 Gr WCB
12	Lock Nut	SS	AS 2837 Gr 316
13	Gasket- Body & Bonnet	HF	HARD FIBRE GASKET
14	Gasket-Dome	HF	HARD FIBRE GASKET
15	Drain Plug	CS	ASTM A 105
16	Ball	SS	AS 2837 Gr 316
17	Stud	AS	ASTM A 193 Gr B7
18	Nut	CS	ASTM A 194 Gr 2H
19	Pinning Screw	CS	ASTM A 193 Gr B7
20	Easing Lever	CS	ASTM A 216 Gr WCB
21	Washer	CS	ASTM F 436
22	Jam Nut	CS	ASTM A 194 Gr 2H
23	Spring Pin	SS	AS 2837 Gr 420

* Recommended spares; available from John Valves. Recommended inspection every 12 months.

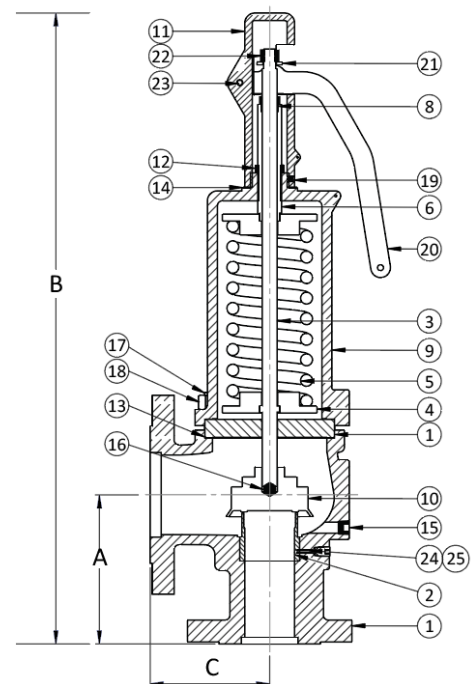

John Valves Pty Ltd Reserve the right to change materials and/or dimensions without notice | 09/2024
 Head Office: 19 Martin Drive, Delacombe, VIC, 3356 | (03) 5336 2113
sales@johnvalves.com.au | johnvalves.com.au

JOHN VALVES
 The Valve People Since 1896

JOHN FIG 74

Safety Relief Valve

Size Range			
Size	Orifice mm ²	Min (Barg) Pressure	Max (Barg) Pressure
DN25 (1")	490.6	0.35	40
DN32 (1-1/4")	803.8	0.35	40
DN40 (1-1/2")	1256	0.35	40
DN50 (2")	1962.5	0.35	40
DN65(2-1/2")	3316.6	0.35	35
DN80 (3")	5024	0.35	32
DN100(4")	7850	0.35	25
DN25 (1")	490.6	0.35	40

Performance		
Size	Over Pressure	Blow Down
Steam	0.05	15%*
Hot Water‡	0.1	10%*
Air/Gas	0.1	20%†
Liquid	0.05	15%*

Maximum Back Pressure	
Barg	5.5
Constant	80%
Built-up	10%
Variable	0%

Figure Numbering

END CONNECTION	OPERATOR	BODY MATERIAL	TRIM	PAINTING	BOLTING	TESTING/ INSPECTION	SPECIAL FEATURES
U	V	4	2	5	1	3	0
UNDRILLED	SAFETY LEVER, SAFETY VALVE	CARBON STEEL	STAINLESS STEEL	SILVER	CARBON STEEL	MILL & HYDRO	
D							
DOME CAP RELIEF VALVE							

AIR CAPACITY CHART [l/s] AT 0.3 Barg or 10% OVERPRESSURE and 15°C							
Set Pressure	DN 25	DN 32	DN 40	DN 50	DN 65	DN 80	DN 100
0.35	69.6	109	178	275	467	711	1098
1.0	115	182	297	459	781	1188	1836
2.0	181	287	468	723	1231	1872	2894
3.0	242	384	626	968	1646	2505	3872
4.0	303	482	786	1215	2066	3144	4859
5.0	365	580	945	1462	2486	3782	5846
6.0	427	678	1105	1708	2906	4421	6834
7.0	488	776	1265	1955	3326	5060	7821
8.0	550	874	1424	2202	3746	5699	8808
9.0	611	972	1584	2449	4165	6337	9795
10.0	673	1070	1744	2696	4585	6976	10783
12.0	796	1267	2063	3189	5425	8253	12757
12.5	827	1316	2143	3313	5635	8573	13251
14.0	920	1463	2382	3683	6265	9531	14732
16.0	1043	1659	2701	4177	7104	10808	16706
18.0	1166	1855	3021	4670	7944	12086	18681
20.0	1289	2051	3340	5164	8784	13363	20655
22.0	1413	2247	3659	5658	9623	14641	22630
24.0	1536	2443	3979	6151	10463	15918	24605
26.0	1659	2639	4298	6645	11303	17196	
28.0	1782	2835	4617	7138	12142	18473	
30.0	1906	3031	4936	7632	12982	19751	
32.0	2029	3227	5256	8126	13822	21028	
34.0	2152	3423	5575	8619	14661		
36.0	2276	3619	5894	9113			
38.0	2399	3815	6214	9607			
40.0	2522	4011	6533	10100			

Other Gases

For application of the valve for other compatible gases, the sizing details above can be used. The valve capacity will change depending on the specific gravity of gas. To calculate the gas capacity, multiply the valve air capacity by $1/\sqrt{SG}$. SG = specific gravity (relative to gas = 1).

Useful Conversions

Nm³/h = 1/sec X 3.60
SCFM = 1/sec X 2.12

*Minimum Overpressure = 0.07 Barg at set pressure less than 1.0 Barg



SATURATED STEAM CAPACITY CHART [kg/h]							
Set Pressure	DN 25	DN 32	DN 40	DN 50	DN 65	DN 80	DN 100
0.35	70	109	178	275	467	711	1098
1.0	115	182	297	459	781	1188	1836
2.0	181	287	468	723	1231	1872	2894
3.0	242	384	626	968	1646	2505	3872
4.0	303	482	786	1215	2066	3144	4859
5.0	365	580	945	1462	2486	3782	5846
6.0	427	678	1105	1708	2906	4421	6834
7.0	488	776	1265	1955	3326	5060	7821
8.0	550	874	1424	2202	3746	5699	8808
9.0	611	972	1584	2449	4165	6337	9795
10.0	673	1070	1744	2696	4585	6976	10783
12.0	796	1267	2063	3189	5425	8253	12757
12.5	827	1316	2143	3313	5635	8573	13251
14.0	920	1463	2382	3683	6265	9531	14732
16.0	1043	1659	2701	4177	7104	10808	16706
18.0	1166	1855	3021	4670	7944	12086	18681
20.0	1289	2051	3340	5164	8784	13363	20655
22.0	1413	2247	3659	5658	9623	14641	22630
24.0	1536	2443	3979	6151	10463	15918	24605
26.0	1659	2639	4298	6645	11303	17196	
28.0	1782	2835	4617	7138	12142	18473	
30.0	1906	3031	4936	7632	12982	19751	
32.0	2029	3227	5256	8126	13822	21028	
34.0	2152	3423	5575	8619	14661		
36.0	2276	3619	5894	9113			
38.0	2399	3815	6214	9607			
40.0	2522	4011	6533	10100			

Other Gases

For application of the valve for other compatible gases, the sizing details above can be used. The valve capacity will change depending on the specific gravity of the gas. To calculate the gas capacity, multiply the valve air capacity by $1/[Equation]SG$. SG = specific gravity (relative to gas = 1).

Useful Conversions

$Nm^3/h = 1/sec \times 3.60$

$SCFM = 1/sec \times 2.12$

*Minimum Overpressure = 0.07

Barg at set pressure less than 1.0 Barg



John Valves Pty Ltd Reserve the right to change materials and/or dimensions without notice | 09/2024

Head Office: 19 Martin Drive, Delacombe, VIC, 3356 | (03) 5336 2113

sales@johnvalves.com.au | johnvalves.com.au



WATER CAPACITY CHART [l/min] AT 10% OVERPRESSURE AT 20°C

Set Pressure	DN 25	DN 32	DN 40	DN 50	DN 65	DN 80	DN 100
0.35	105	167	272	420	715	1088	
1.0	170	270	440	680	1157	1761	2722
2.0	240	382	622	962	1637	2490	3849
3.0	294	468	762	1178	2005	3050	4714
4.0	340	540	880	1361	2315	3522	5443
5.0	380	604	984	1521	2588	3937	6086
6.0	416	662	1078	1667	2835	4313	6666
7.0	449	715	1164	1800	3062	4659	7210
8.0	481	764	1245	1924	3273	4980	7698
9.0	510	811	1320	2041	3472	5282	8165
10.0	537	854	1392	2152	3660	5568	8606
12.0	589	936	1525	2357	4009	6099	9428
12.5	601	955	1556	2406	4092	6225	9622
14.0	636	1011	1647	2546	4330	6588	10183
16.0	680	1081	1760	2722	4629	7043	10886
18.0	721	1146	1867	2887	4910	7470	11547
20.0	760	1208	1968	3043	5176	7874	12171
22.0	797	1267	2064	3191	5428	8259	12765
24.0	832	1324	2156	3333	5670	8626	13332
26.0	866	1378	2244	3469	5901	8978	
28.0	899	1430	2329	3600	6124	9317	
30.0	931	1480	2410	3727	6339	9644	
32.0	961	1528	2490	3849	6547	9960	
34.0	991	1575	2566	3967	6748		
36.0	1019	1621	2641	4082			
38.0	1047	1666	2713	4194			
40.0	1074	1709	2783	4303			

Other Temperatures

The above steam table is based on saturated steam. For steam systems operating at higher temperatures, the above capacities will need to be derated by using the super superheat correction factor.

Useful Conversions

lbs/h = kg/h X 2.2046

Minimum overpressure = 0.07 Barg at set pressure less than 0.7 Barg.

HOT WATER CAPACITY CHART (kW) FOR A PRESSURISED (un-vented) SYSTEM

Set Pressure	DN 25	DN 32	DN 40	DN 50	DN 65	DN 80	DN 100
0.35	105	167	272	420	715	1088	
1.0	170	270	440	680	1157	1761	2722
2.0	240	382	622	962	1637	2490	3849
3.0	294	468	762	1178	2005	3050	4714
4.0	340	540	880	1361	2315	3522	5443
5.0	380	604	984	1521	2588	3937	6086
6.0	416	662	1078	1667	2835	4313	6666
7.0	449	715	1164	1800	3062	4659	7210
8.0	481	764	1245	1924	3273	4980	7698
9.0	510	811	1320	2041	3472	5282	8165
10.0	537	854	1392	2152	3660	5568	8606
12.0	589	936	1525	2357	4009	6099	9428
12.5	601	955	1556	2406	4092	6225	9622
14.0	636	1011	1647	2546	4330	6588	10183
16.0	680	1081	1760	2722	4629	7043	10886
18.0	721	1146	1867	2887	4910	7470	11547
20.0	760	1208	1968	3043	5176	7874	12171
22.0	797	1267	2064	3191	5428	8259	12765
24.0	832	1324	2156	3333	5670	8626	13332
26.0	866	1378	2244	3469	5901	8978	
28.0	899	1430	2329	3600	6124	9317	
30.0	931	1480	2410	3727	6339	9644	
32.0	961	1528	2490	3849	6547	9960	
34.0	991	1575	2566	3967	6748		
36.0	1019	1621	2641	4082			
38.0	1047	1666	2713	4194			
40.0	1074	1709	2783	4303			

Other Temperatures

The above steam table is based on saturated steam. For steam systems operating at higher temperatures, the above capacities will need to be derated by using the super heat correction factor.

Useful Conversions

lbs/h = kg/h X 2.2046

Minimum overpressure = 0.07 Barg at set pressure less than 0.7 Barg.