

# JOHN FIG 848

## Safety Valve

The John Fig 848 is a safety valve designed in Bronze, designed to comply with standard AS1271. Primarily implemented for steam applications, this valve boasts a robust stainless-steel disc and seating arrangement, ensuring reliable performance under demanding conditions. With its capability to operate at temperatures up to 225 Celsius, it stands as a dependable safeguard in various industrial settings.

w

<b>Body</b>	Gunmetal Bronze
<b>Trim</b>	Stainless Steel
<b>Size Range</b>	15, 20, 25, 32, 40, 50
<b>Pressure Rating</b>	PN15
<b>Pressure Range</b>	1.0 to 12.0 bar (Std. Spring) 10.0 to 20.0 bar (HD Spring)
<b>Temperature</b>	-196°C - 225°C
<b>Connection</b>	BSP ( MALE ) X BSP ( FEMALE )
<b>Standards</b>	AS1271, Class B

### Dimensions

P1 (BSP)	P2 (BSP)	D (in)	LIFT (mm)	L1 (mm)	L2 (mm)	H1 (mm)	Kg
½	17	¾	15	36	54	167	0.73
¾	21	1	20	40	66	200	1.3
1	28	1 ¼	25	50	76	216	1.89
1-1 ¼	36	1 ½	32	57	92	246	2.48
1 ½	43	2	40	65	102	285	4.02
2	56	2 ½	50	76	110	300	5.55

### Materials of Construction

ID	DESCRIPTION	MATERIAL	Specification
1	BODY	Gunmetal Bronze	AS 1565 Gr C83600
2	BASE (SEAT)	Stainless Steel	ASTM A276 Gr.316
3	DISC	Stainless Steel	ASTM A276 Gr.304
4	STEM	Stainless Steel	ASTM A276 Gr.304
5	SPRING	Oil Tempered Steel	Can vary

### Steam Blowout Capacity Kg/Hour @ 3% Overpressure

Set Press	½" / ¾"	¾"/1"	1"/1¼"	1 ¼"/1 ½"	1 ½" / 2"	2"/2 ½"
<b>kPa</b>	<b>15/20</b>	<b>20/25</b>	<b>25/32</b>	<b>32/40</b>	<b>40/50</b>	<b>50/65</b>
200	93	174	307	513	650	1117
300	125	233	399	678	872	1498
400	157	292	491	843	1094	1880
500	189	352	583	1008	1316	2261
600	221	411	675	1173	1538	2642
700	253	470	767	1338	1760	3023
800	284	530	860	1503	1982	3405
900	316	589	952	1668	2204	3786
1000	348	648	1044	1833	2426	4167
1100	380	708	1136	1998	2648	4548
1200	412	767	1228	2163	2870	4929
1300	444	827	1320	2328	3092	5311
1400	476	886	1412	2493	3315	5692
1500	508	945	1505	2658	3537	6073

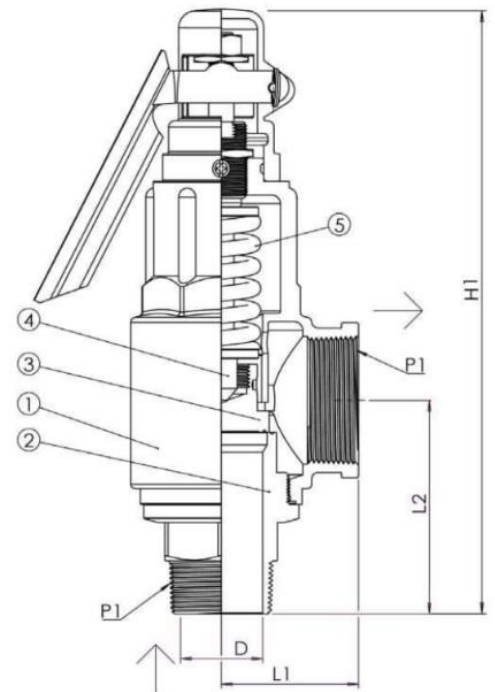

\* Recommended spares; available from John Valves. Recommended inspection every 12 months.



John Valves Pty Ltd Reserve the right to change materials and/or dimensions without notice | 03/2024  
**Head Office:** 19 Martin Drive, Delacombe, VIC, 3356 | (03) 5336 2113  
[sales@johnvalves.com.au](mailto:sales@johnvalves.com.au) | [johnvalves.com.au](http://johnvalves.com.au)

**JOHN VALVES**  
 The Valve People Since 1896